

BIKE-SHOPPER QL2.1

DE MONTAGEANLEITUNG
GB ASSEMBLY INSTRUCTIONS
FR INSTRUCTIONS DE MONTAGE

IT ISTRUZIONI DI MONTAGGIO
NL MONTAGE HANDLEIDING
DK MONTERINGSVEJLEDNING

ES INSTRUCCIONES DE MONTAJE
SE MONTERINGS ANVISNING
NO MONTERINGS ANVISNING

FI ASENNUSOHJEET
PL INSTRUKCJA MONTAZU
JP 装着方法



QL2.1 - MODELS

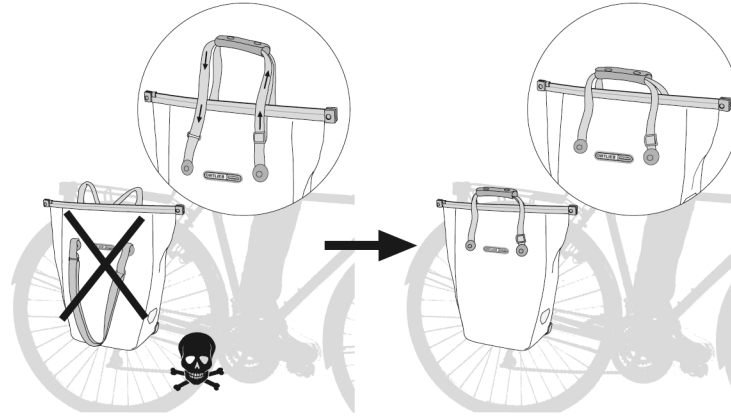
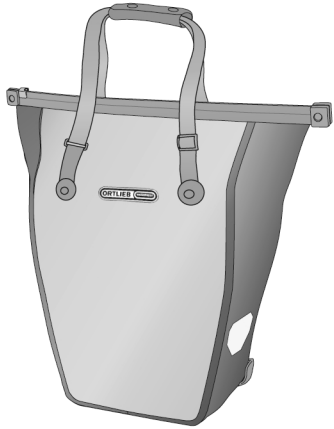

ACCESSORIES

= + Art. #F35

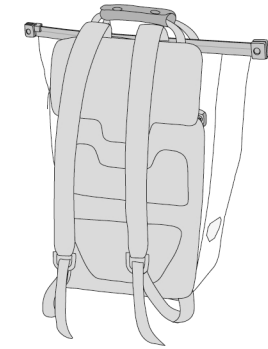

= + Art. #E193

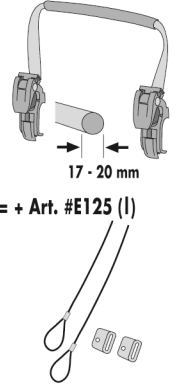

QL2.1

A

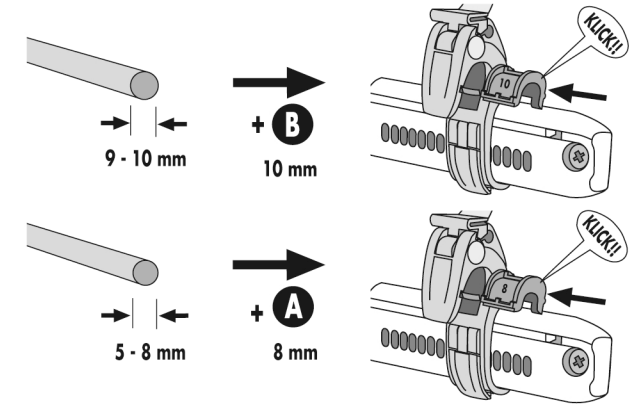
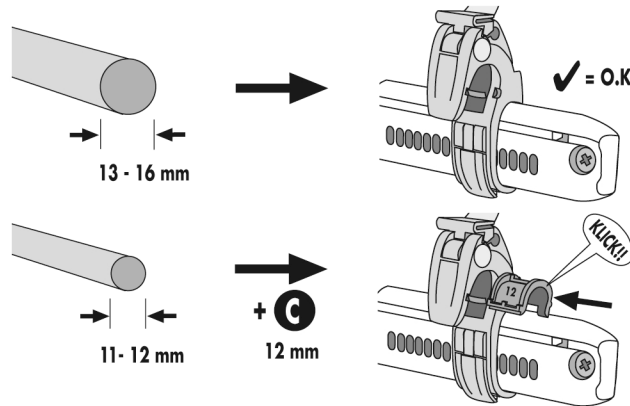
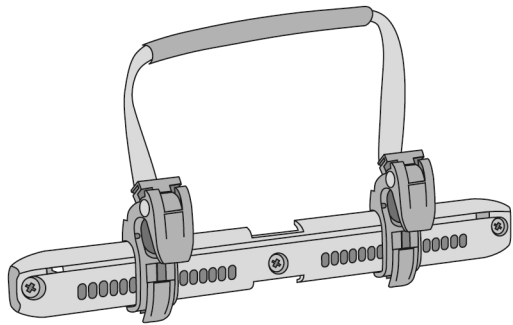

= **A** 8 mm = **B** 10 mm = **C** 12 mm

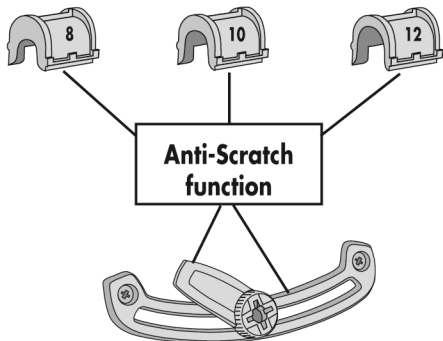

B

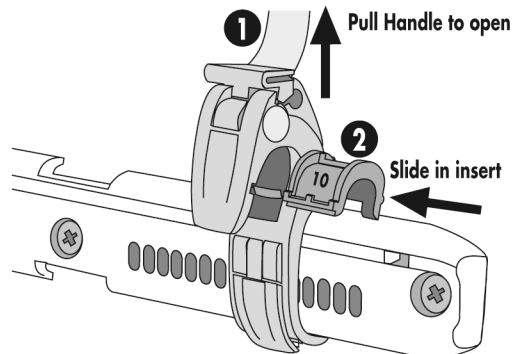

C

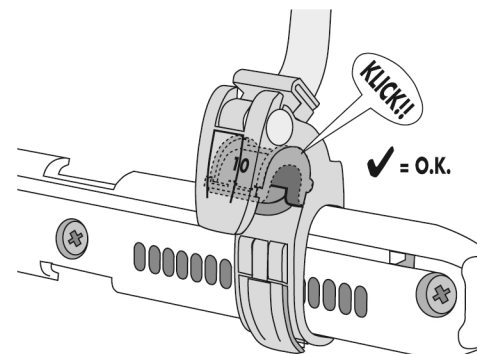

D

